

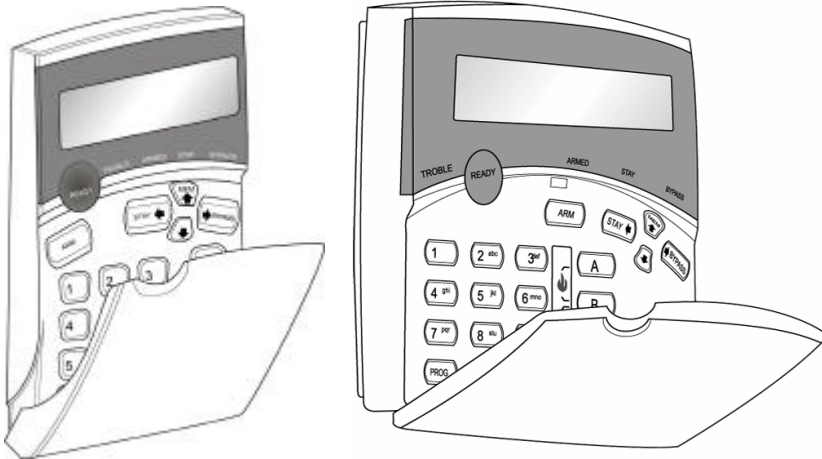

ELECTRONIC ENGINEERING LTD.

Power Wave CR16M- LCD Keypad



Users' Operating and Programming Guide Version 2.

P/N 7102265 Rev. C N.A

May 2003

Contents

Introduction	4
Meet the Crow Alarm Control System	4
Typical Alarm System Configuration	4
Keypad Description	5
General Description	5
Function Keys	5
Alphanumeric Keys	5
Audible Signals	5
Indicators	6
Display	6
Summary of Functions	7
Operation	9
How to Arm the System before Exit	9
How to Arm the System when Staying Home	10
How to Arm Partitions	11
How to Bypass Zones	11
How to use Chime (If enable by Installer)	12
Generate Threat or Duress	12
How to Read System Messages	13
How to Read Trouble Messages	13
How to Display Events from Memory	14
How to Control Outputs and Devices	14
User Programming and Customization	14
How to Get into to User Program/Client Mode	14

How to Change or Add Codes	14
Customizing your Keypad	16
How to Add or Change Telephone Numbers	16
How to set Time and Date	17
How to operate the access control output	18
How to start Walk test Mode	18
How to Adjust Keypad Backlight Level	20
How to Adjust Buzzer Tone	20
PowerWave – LCD Keypad Assignment	23

Introduction

Meet the Crow Alarm Control System

Thank you for choosing to protect your premises with a **PowerWave** of Crow Electronic Engineering Ltd.

Power Wave of Crow Electronic Engineering Ltd. is a highly advanced, multifunction alarm control system, designed to flawlessly manage your security system at home or at business, protects you against burglary and supports the operation of electronic devices.

The PW has many incredible program options and additional accessories that can enhance the standard features of the panel from simple "Home Automation" to "Radio control" and Voice Prompted Command control". Please ask your installer to find out more about these powerful features.

You can phone You can phone your home to check or change the status of any output using the keys on your phone. Arm or disarm the whole house or just one area, all with your own voice confirming your selections.

Imagine turning on the spa before leaving work so it is hot when you get in the door. The under-floor heating has just automatically switched on using the on board timer and you have just opened the rollerdoor and disarmed the garage from your cell phone so the white ware repairman can work on your washer.

The controller will support a 16 LED keypad or the more sophisticated LCD (liquid Crystal Display) keypad.

It also has a comprehensive alarm event memory that stores all of the controller activity with the time and date.

Typical Alarm System Configuration

The protected premises can be divided up to 64 zones, as defined by the installation scheme. The protected area can be grouped upto 4 separate partitions (A,B,C,D). The system can be grouped for User 's convenience to separate, in a business environment, the offices from the warehouse area, or in a private residence, the different rooms of the home, e.g., living room, bedroom, etc.

Each zone can react differently to various events, to generate an alarm or activate a device.

The system can be armed in two different modes:

- 1) Arm –the protected areas are entirely vacated
- 2) Stay –people and pets populate the protected areas.

The User who has access to the keypad's control features, can change the settings.

The system can be accessed via multiple keypads (each located at a different site). Up to 8 keypads can be integrated into the system. Access levels and Users' access codes are detailed below.

Keypad Description

General Description

The LCD display shows all the information required to operate the system in a friendly manner and free of flaws. The User communicates with the alarm system via the keypad. The Keypad displays continuous information about the status of the alarm system, and enables the User to operate the system in different modes, change settings and program Users' access codes.

The keypad also collects and records events to be displayed afterward on request, to overview system activities, and to analyze system performance for diagnostics.

The keyboard is illustrated in Figure 1, and the main components are detailed below.

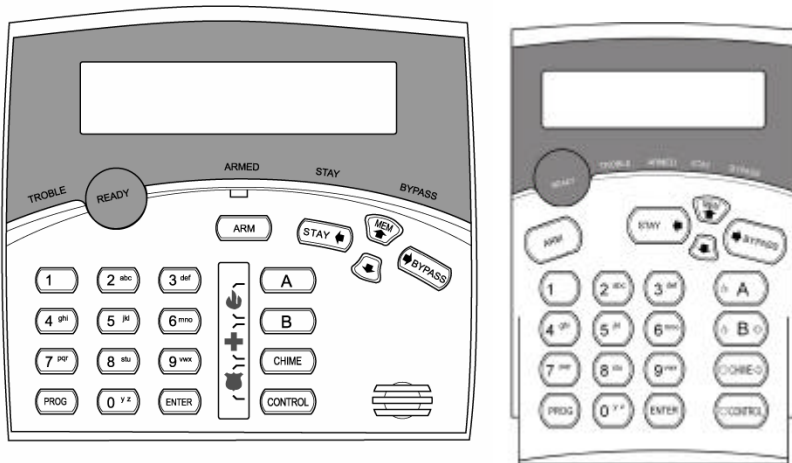

Figure 1: Keypad

Function Keys

These keys are used to arm the system, enter commands to alter system settings, or scroll through the display.

Alphanumeric Keys

These keys are used to enter codes, change descriptions of zones, or for programming.

Audible Signals

The keypad emits signals (beeps) in response to User activities. These signals are listed in Table 1.

Table 1: List of Audible Signals

Sound	Sequence	Description
Short beep	Once only	A key in the keypad has been pressed
3 short beeps	Once only	Operation carried out successfully
Long beep	Once only	Illegal operation, or wrong key pressed
Slow beeping	Through the Exit or Entry delay time	Exit or entry delay warning when arming the system indicates that you must exit the protected area, also Entry delay warning when entering via the entry zone, to disarm the system.

Indicators

The indicators show the status of the system. The LED indicators are listed in Table 2.

Table 2: List of LED Indicators

Design.	Function
Bypass	Indicates that there are bypassed zones
Stay	Indicates that the system is armed in STAY mode
Armed	Indicates that the system is fully armed, or a partition is armed
Ready	Indicates that the system is ready to be armed
Trouble	Indicates system failure, or problem. Make note of system message and call service

Display

The LCD window holds 2 rows of 16 characters each.





















The display shows:













- System Messages
- Open Zones
- System Status
- Trouble Messages
- Memory Events
- Description of zones
- Zone numbers during programming
- Device numbers during control







Summary of Functions

The system's main functions are listed in Table 3.

Table 3: Summary of Functions

Function	Keys	Description	Notes
Full or Partition Arm	 C O D E  ENTER	Initiates full arm	
Full Arm	 ARM	Initiates full arm	Only if enabled by installer
Disarm during exit	 ARM	Disarms the system during exit delay	Only when slow beeping is emitted
Disarm	 C O D E  ENTER	Disarms the system	Stopping Alarms
Arm Partition	 A or  B	Arms partition A or B	Press A or B for 2 seconds to arm relevant partition Only if enabled by installer
Arm Stay	 STAY  C O D E  ENTER	Initiates partial alarm when the user is home	Only if enabled by installer
Arm Stay	 STAY	Initiates partial alarm when the user is home	
Disarm Stay	 C O D E  ENTER	Disarms the system	
Disarm Stay	 STAY	Disarms the system	
Bypass	 BYPASS  Zone #   ENTER	Bypasses a zone(s)	Repeats the procedure to un-bypass zones
Initiate Panic	 CHIME + CONTROL	Activates emergency alert	Press simultaneously for 2 seconds
Initiate Medical Alarm	 CHIME + B	Activates emergency alert	Press simultaneously for 2 seconds

Function	Keys	Description	Notes
Initiate Fire Alarm	 A + B	Activates emergency alert	Press simultaneously for 2 seconds
Memory	 MEM	Initiates display of events from memory. <ENTER> cancels memory readout	Displays events, and automatically scrolls to the next event every 2.5 sec. (Use arrow key to scroll up manually)
Chime Enable/disable	 CHIME	Enable or disable chime function	Holds the key for 2 sec to alternate. Only if enabled by installer
Control	 CONTROL  Device#  ENTER	Activates or deactivates outputs and devices	Press <Control> for 2 seconds
Change or Add Users' code	 PROG  M CODE  ENTER	Activates program mode to add or change Users' codes	For details see page 14
Customize keypad	 CONTROL + ARM	Enters Local Edit Program Mode	Press Control and then Arm, and hold both simultaneously for 2 sec For details see page 16
Increase LCD backlight level	 CONTROL + STAY	Hold <CONTROL> and press <STAY> repeatedly to increase light	
Decrease LCD backlight level	 CONTROL + BYPASS	Hold <CONTROL> and press <BYPASS> repeatedly to decrease light	
Increase LED backlight level	 CONTROL + MEM	Hold <CONTROL> and press <MEM> repeatedly to increase light	

Function	Keys	Description	Notes
Decrease LED backlight level	 CONTROL + 	Hold <CONTROL> and press <? > repeatedly to decrease light	
Increase buzzer tone	 CONTROL + 	Hold <CONTROL> and press <A> repeatedly to increase buzzer tone	
Decrease buzzer tone	 CONTROL + 	Hold <CONTROL> and press repeatedly to lower buzzer tone	

Note: If you started an operation incorrectly, press <ENTER> to exit and return to the previous mode.

Operation

How to Arm the System before Exit

- **Preparing the System for Arming**

Verify that the green <Ready> indicator is lit. This indicator is lit only when all zones are closed (all doors, exits and windows are closed and motion in the protected area is restricted or bypassed). If the green <Ready> indicator is not illuminated, the LCD displays the open zones and descriptions.

Close open zones, or bypass them. Bypass any zone you cannot close. For details see page 11.

Note: Bypassed zones are not protected.

- **Arming the System**

PowerWave XX
 DATE TIME

When the system is ready, the LCD display shows the system type, date and time, and the green <Ready> indicator is lit.

Before leaving premises the system has to be armed.

When the system is Ready, **enter user code** and then <ENTER> to arm the system.

Enter Code

The system prompts you to exit the protected area.

Areas Exiting
A -

There is a exit delay prior to the system being armed. During this delay time you can leave the premises. At the end of the procedure, the ARMED indicator lights up to indicate that the system is armed, and the system message is displayed. (The indicators may go out after a few seconds, depending on the installer's setting).

Areas Armed
A -

- **Quick Arm**

When enabled by the installer, press <ARM> to arm the system.

During this delay time, a slow beeping is heard to indicate that the system is not armed yet and reminds you to leave the protected area..

If you must disarm the system during the exit delay, press <ARM>.

- **Disarming the System**

Enter **User's code** and press <ENTER>.

The following system message is displayed:

Areas Disarmed
A -

- **Stopping Alarms**

Enter **User's code** and press <ENTER> to stop alarm any time.

How to Arm the System when Staying Home

- **Arming the System in Stay Mode**

This type of arming is used when people are present within the protected area. At night time, when the family is about to retire , perimeter zones are protected, but not the interior zones. Consequently, interior movements will be ignored by the system.

When the system is Ready, **press <STAY>** and the system prompts you to **enter user code**, and then <ENTER>.

Enter Code

- **Quick Stay**

When enabled by the installer, press <STAY> to arm the system.

During exit delay you can leave the premises. If you wish to stay or that no one will enter the protected premises, you may cancel the Entry/exit delay by pressing the <ENTER> key. The slow beeping stops and the system is immediately armed.

At the end of the procedure, the Stay indicator lights up to indicate that the system is armed and the system message is displayed. (The indicators may go out after a few seconds, depending on the installer's setting).

Areas In Stay
A -

- **Disarming the System**

Enter **user's code** and press <ENTER>, or press <STAY> if enabled by installer.

The following system message is displayed.

Areas Disarmed
A -

How to Arm Partitions

The protected area can be grouped into two separate partitions (e.g. A , B and C).. The system can be grouped for User 's convenience to separate, in a business environment, the offices from the warehouse area, or in a private residence, the different rooms of the home, e.g., living room, bedroom, etc.

To arm partition A or B or C see Para "Arming the System".

If enabled by the installer, to arm the partition A, **press <A> for 2 seconds.**

To arm partition B, **press for 2 seconds**

The same procedure is also applicable to partition B.

Areas Exiting
- B -

During exit delay you can leave premises. At the end of the procedure the ARMED indicator lights up to indicate that the system is armed and system message is displayed. (The indicators may go out after a few seconds, depending on the installer's setting).

Areas Armed
- B -

To disarm partition, see "Disarming the System".

Note: to arming partition with code see page 9 "How to arm the system before exit"

How to Bypass Zones

Bypass any zone that cannot be closed. You can bypass selected zones prior to arming. It is also used to temporarily exclude a faulty zone from service, which requires repair.

To bypass a selected zone, press <BYPASS>, Bypass indicator lights up to indicate that the system is in bypass mode.

Enter the **zone number (e.g. 01, 05, 12 in PW16 or 1, 2, 6 in PW4/8)** one or more zones.

Bypass Zones
01 03 06

Following press **<ENTER>**, the system displays the bypassed zones.

Zone 3 Bypass
Zone 3

While in the Bypass mode it is possible to bypass more than one zone, press **<BYPASS>**, Bypass indicator lights up to indicate that the system is in bypass mode,

Add the **zone number (e.g. 03)** one or more zones, following press **<ENTER>** , the Bypass indicator lights up to indicate zone(s) bypassed .

To un-bypass zones, press **<BYPASS>**, enter **zone number (e.g.07,13)** and press **<ENTER>**.

Note: Disarming automatically un-bypasses all zones.

How to use Chime (If enable by Installer)

To disable this function, press **<CHIME>** for 2 seconds, as shown below.

Chime OFF

To enable this function, press **<CHIME>** for 2 seconds, as shown below.

Chime ON

Emergency Alerts

How to initiate Panic

Press simultaneously **<CHIME>** and **<CONTROL>** for 2 seconds.

How to initiate Medical Alarm

Press simultaneously **<CHIME>** and **** for 2 seconds.

How to initiate Fire Alarm

Press simultaneously **<A>** and **** for 2 seconds.

Generate Threat or Duress

If you are compelled to disarm the system under threat, you must enter the duress digit before the user's code to activate the automatic dialer. The duress digit shifts up your

usual code by one digit. If your code is 345 and 8 is your duress digit, than entering 8345 will modify your code. The modified duress code will disarm the system in a normal way, but at the same time will activate the dialer silently to report a "duress event" without arousing suspicion. (For details ask installer.)

How to Read System Messages

Any system failure that may occur, is indicated by system messages. System messages are automatically displayed and are listed in Table 4. Read messages and call for service.

Table 4: System Messages

Message	Description/Action
Battery Low	The backup battery is low (charger or battery failure)
Main Failure	The main power is disconnected, or caused by power outage.
Telephone Line Failure	The line is disconnected
Radio Device Battery Low	Replace battery of the particular device
Supervise Detector Failure	Radio detector failed to communicate
Zone Inactivity Time-out	No movement detected during expected time in this zone
Dialer Kiss-off Failure	Communication fail

How to Read Trouble Messages

Any failure or -abnormal events that may occur are indicated by trouble messages, and the Trouble indicator is lit. **Press <MEM>** to read out messages and other events stored in memory. Trouble messages are listed in Table 5.

Table 5: Trouble Messages

Message	Description/Action
Zone Tamper	The tamper of a particular zone
System Tamper	Main cabinet open
Pendant Panic	Panic alarm initiated via radio pendant
Panic	Panic alarm initiated via keyboard
Fire	Fire alarm initiated via keyboard
Medical	Medical alarm initiated via keyboard
Duress code used	Duress digit pressed by one of the users, under threat

How to Display Events from Memory

The system memory stores the last events. **Press <MEM>** to display list of events. The system will display the last event and automatically scroll to the next one every 2.5 seconds, and a beep is emitted. Use the arrow keys to scroll up manually. Each entry shows the type of event, date and time. Wait until all messages are displayed, or press **<ENTER>** to cancel memory readout.

If the message exceeds 16 characters, use the right arrow to read the message.

How to Control Outputs and Devices

The keypad enables control of external devices, such as an air-conditioner or heater. To activate or halt a device, **press <CONTROL>** for 2 seconds and the **number of the device**. Up to 8 different devices can be controlled via the keypad.

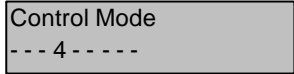

```
Control Mode
--- 4 ---
```

When you enter control mode the system prompts you to enter device # and then **<ENTER>** to activate or deactivate the selected device.

User Programming and Customization

How to Get into to User Program/Client Mode

There are 2 levels of program mode, **CLIENT** mode and **INSTALLER** mode. Normally the installer will give you access to the **CLIENT** mode so you can add, delete, or change the user codes. If you request it your installer can provide you with access to the **INSTALLER** mode as well. To get into **CLIENT** mode provided the system is NOT armed Press **<PROGRAM>** enter **Master code** and **<ENTER>**.

If you get a single long beep at this point , it means your code cannot access Program mode.

- How to exit program mode

To exit out of program mode press **<PROGRAM>** and **<ENTER>**.

The LCD display shows the system type, date and time.

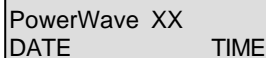

```
PowerWave XX
DATE          TIME
```

How to Change or Add Codes

About Master code and User code

The factory default master code (123) is intended as a preliminary control of the alarm system. After PowerWave is installed and put into service, the code can be changed to any code known to the Master user. The Master user can define up to 99 user codes. To limit access rights, the holder of the Master code can ask the installer to define several User profiles.

Access rights are listed below:

- User code has Area A and/or B or C permission
- User code can arm and/or disarm arm an area
- User code can arm and/or disarm arm an area in Stay mode
- User code can change its code
- User code can change user's code
- User code can Operate control Functions
- User code can change dialer telephone numbers
- User code can alter the real time clock
- User can answer an incoming call and start up/down load
- User can allow access to installer program mode from client mode.
- Initiate Walk-test mode.

How to Change Master Code

Press <PROG> enter **Master code** and <ENTER>. The display will show "Client Mode".

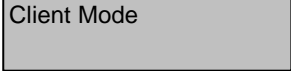

Client Mode

Press <PROG> and **1** to change Master code. Use the numeric keyboard to enter your new Master code. The code can hold any combination of 1 to 6 digits. It is recommended using a multi-digit code. . Press <ENTER> to save your new code. To proceed to the next user code, Press <MEM>. Press <PROG> and <ENTER> exit Client Program mode.

How to Add or Change User Code

In client mode, press <PROG> and the **User number** (2 to 100) to add or change the code. Use the numeric keyboard to enter the new code. The code can hold any combination of 1 to 6 digits. Press <ENTER> to **save** your new code.

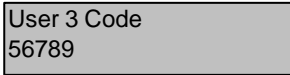

User 3 Code
56789

Repeat the procedure for all users or use arrow (MEM) key to advance to next user.

Press <PROG> and <ENTER> to exit Local Program mode.

How to Delete User Code

In client mode, press **<PROG>** and the **User number** (2 to 100) you intend to delete. The display shows the code.

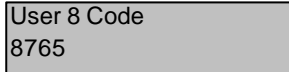

User 8 Code
8765

Press **<CONTROL>** and **<0>** simultaneously to delete User code. Press **<ENTER>** to **save** the change.

Press **<PROG>** and **<ENTER>** exit Client Program mode.

Customizing your Keypad

Local Edit Program mode assists the user to customize descriptions, adjust keypad light and buzzer tone.

How to Enter Local Edit Program Mode to Describe Zones

To enter this mode, **press simultaneously <CONTROL> and <ARM> for 2 seconds**. The display will show "Local Mode kb #". From hereon, you can change the numeric description of a zone to a textual description.

Press <PROG> <1> to change the description of Zone 1. For example, Use the arrow keys to move the cursor forward or backward on the display. Press the corresponding key to replace the current digit. Each key represents 3 different characters. The first character will be shown at the first press, etc. **Press <MEM>** to change from **uppercase to lowercase** and visa-a-versa.

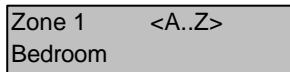

Zone 1 <A..Z>
Bedroom

During the programming of text for all of the addresses 1-8,998,999 you can also use the **<A>** button to return back to last saved text and you can use **** button to return back to the default text.

Press **<ENTER>** to save textual description.

For more zones, press **<PROG>**, followed by Zone # to continue textual description.

The functions of the alpha-numeric keys are listed in Table 6.

How to Add or Change Telephone Numbers

Your panel will accept up to 6 phone numbers with a total of 16 digits. Your panel can be programmed to dial all or any of these depending on the event which has occurred.

(In PW16 The six phone numbers are at program address 331 through to 336).

(In PW4/8 The six phone numbers are at program address 501 through to 504).

(In FW64 – see User's Operating and Programming guide)

While in **CLIENT** mode, key in the following sequence **<PROGRAM> <331> <ENTER>**

(The address for telephone number 1), The existing number will be flashed out at the

Keypad then enter **<NEW TELEPHONE #> <ENTER>** The new numbers will be flashed back to confirm acceptance.

At any time you can enter in the address for the telephone number just to view the currently programmed value then press the **<PROGRAM>** button to move on to another address.

Note: In PW16 Address 331 = PH # 1, 332 = PH# 2 to 336 = PH# 6.

Note: In PW4/8 Address 501 = PH # 1, 502 = PH# 2 to 504 = PH# 4.

How to set Time and Date

The alarm system has an internal clock that may be used to automatically Arm or Disarm the alarm or turn Outputs On or off. It is also used to identify when events occurred in memory via the LCD keypad. Should you need to change the Time & Date it must be done from **CLIENT** mode.

To change the Time & Date press

In PW16 - Press **<PROGRAM> <823> <ENTER> <1-7> <ENTER>**

In PW4/8 - Press **<PROGRAM> <403> <ENTER> <1-7> <ENTER>**

(In FW64 – see User's Operating and Programming guide)

Where 1-7 = the current day (1=Sun, 2 = Mon to 7 = Sat)

In PW16 - Press **<PROGRAM> <824> <ENTER> <HHMM> <ENTER>**

In PW4/8 - Press **<PROGRAM> <401> <ENTER> <HHMM> <ENTER>**

Where HH = Hour in 24 Hour Format and MM = Minutes

In PW16 - Press **<PROGRAM> <825> <ENTER> <1-31> <ENTER>**

In PW4/8 - Press **<PROGRAM> <405> <ENTER> <1-31> <ENTER>**

Where 1-31 = the current date

In PW16 - Press **<PROGRAM> <826> <ENTER> <1-12> <ENTER>**

In PW4/8 - Press **<PROGRAM> <406> <ENTER> <1-12> <ENTER>**

Where 1-12 = the current month

In PW16 - Press **<PROGRAM> <827> <ENTER> <YY> <ENTER>**

In PW4/8 - Press **<PROGRAM> <407> <ENTER> <YY> <ENTER>**

Where YY = current year, e.g. 02=2002

How to operate the access control output

If the alarm system has been set up to allow control of an electric door lock, you can activate the door release function as follows;

Press **<CONTROL>** or Press **<CONTROL>** enter **CODE** then **<ENTER>**

The Control LED will lights up while the lock is active and turn off as soon as power is removed from the lock.

The Access Control function can either be a single button operation or restricted to requiring a valid User code entry. Both options are shown above. Please consult your installer as to what option may be programmed.

How to start Walk test Mode

In PW16 only - While in **CLIENT** mode a User with the proper authority can start walk-test mode. This special mode latches the alarm signals from detectors at the keypad initiating the test so that one person can trigger every detector connected to the alarm then return to the keypad to verify operation. On terminating Walk-test mode the test results are put into the memory buffer so they can be viewed at a later time.

To start Walk-test mode while in **CLIENT** mode press **<PROGRAM>** **<836>** **<ENTER>**

The keypad buzzer will beep at 1-second intervals

Next trigger every detector connected to the panel then return to the keypad and all of the zones that were triggered will be displayed at the keypad.

To terminate Walk-test mode press **<ENTER>**

The keypad will stop beeping and automatically exit **CLIENT** mode.

(In FW64 – see User's Operating and Programming guide)

How to Answer an in-coming call

In PW16 only - From time to time your installer may need to access the alarm from a remote PC to make changes to your programming and for security reasons they may have configured the alarm so that an authorized person on-site is required to make the alarm system answer the in-coming call. This option is only available in **CLIENT** mode.

To answer an In-coming Call press **<PROGRAM>** **<835>** **<ENTER>**

Provided the line connected to the alarm was ringing at the time the panel will now answer the call and allow a remote PC connection.

Table 6: Summary of Alphanumeric Keys

Button #	1 st Press	2 nd Press	3 rd Press	4 th Press
1	* (')	# (<)	= (>)	1
2	A (a)	B (b)	C (c)	2
3	D (d)	E (E)	F (F)	3
4	G (g)	H (h)	I (i)	4
5	J (j)	K (k)	L (l)	5
6	M (m)	N (n)	O (o)	6
7	P (p)	Q (q)	R (r)	7
8	S (s)	T (t)	U (u)	8
9	V (v)	W (w)	X (x)	9
0	space	Y (y)	Z (z)	0

How to Program System Description

While in Local Edit Program Mode Press **<PROG>** **<999>** and then **<ENTER>**. You may enter any name for your system (up to 16 characters).

Name	<A..Z>
Johnson Family	

To **save** changes, press **<ENTER>**.

How to Program Area Description

While in Local Edit Program Mode Press **<PROG>** **<998>**, and then **<ENTER>**. You may edit any character, one per each area.

Areas	<A..Z>
ABCDEFGHIJKLMNPO	

To **save** changes press **<ENTER>**.

To update and transfer programmed textual information from one LDC keypad to another, press **<CHIME>** for 2 seconds.

To **exit** Local Edit Program Mode and return to Idle Mode, press **<PROG>** and then **<ENTER>**.

How to Adjust Keypad Backlight Level

The User can adjust the backlight of the keys and LCD display in 16 steps, from Fully illuminated to Off.

To increase LCD backlight, hold **<CONTROL>** and press **<STAY>** repeatedly until the light is increased to its maximum.

To decrease LCD backlight, hold **<CONTROL>** and press **<BYPASS>** repeatedly until the light goes off.

To increase keyboard backlight, hold **<CONTROL>** and press **<MEM>** repeatedly until the light is increased to its maximum.

To decrease keyboard backlight, hold **<CONTROL>** and press **<? >** repeatedly until the light goes off.

How to Adjust Buzzer Tone

The User can adjust the volume of the buzzer tone can be adjusted, in 16 steps, from fully On to Off.

To increase the volume, hold **<CONTROL>** and press **<A>** repeatedly until it is increased to its maximum.

To decrease the volume, hold **<CONTROL>** and press **** repeatedly until it is decreased to off.

Warranty

CROW LIMITED WARRANTY

(Crow) warrants this product to be free from defects in materials and workmanship under normal use and service for a period of one year from the last day of the week and year whose numbers are printed on the printed circuit board inside his product.

Crow's obligation is limited to repairing or replacing this product, at its option, free of charge for materials or labor, if it is proved to be defective in materials or workmanship under normal use and service. Crow shall have no obligation under this Limited Warranty or otherwise if the product is altered or improperly repaired or serviced by anyone other than Crow.

There are no warranties, expressed or implied, of merchantability or fitness for a particular purpose or otherwise, which extend beyond the description on the face hereof. In no case shall Crow be liable to anyone for any consequential or incidental damages for breach of this or any other warranty, expressed or implied, or upon any other basis of liability whatsoever, even if the loss or damage is caused by Crow's own negligence or fault.

Crow does not represent that this product can not be compromised or circumvented; that this product will prevent any person injury or property loss or damage by burglary, robbery, fire or otherwise; or that this product will in all cases provide adequate warning or protection. Purchaser understands that a properly installed and maintained product can only reduce the risk of burglary, robbery or other events occurring without providing an alarm, but it is not insurance or a guarantee that such will not occur or that there will be no personal injury or property loss or damage as a result. Consequently, Crow shall have no liability for any personal injury, property damage or any other loss based on claim that this product failed to give any warning. However, if Crow is held liable, whether directly or indirectly, for any loss or damage arising under this limited warranty or otherwise, regardless of cause or origin, Crow's maximum liability shall not in any case exceed the purchase price of this product, which shall be the complete and exclusive remedy against Crow.

Use the following form to record your changes and customizations.

User #	Name	Out put #	Device Designation	Zone #	Zone Name
1		1		1	
2		2		2	
3		3		3	
4		4		4	
5		5		5	
6		6		6	
7		7		7	
8		8		8	
9				9	
10				10	
11				11	
12				12	
13				13	
14				14	
15				15	
16				16	
17					
18					
19					
20					
21					
22					
23					
24					
25					

PowerWave – LCD Keypad Assignment

Each of the 8 possible LCD keypads that can be connected to your PW control Panel must be set to the suitable type of control panel, and addressed individually to avoid bus conflicts.

To assign the KEYPAD Address

	Switch 1	Switch 2	Switch 3
Keypad #1	OFF	OFF	OFF
Keypad #2	ON	OFF	OFF
Keypad #3	OFF	ON	OFF
Keypad #4	ON	ON	OFF
Keypad #5	OFF	OFF	ON
Keypad #6	ON	OFF	ON
Keypad #7	OFF	ON	ON
Keypad #8	ON	ON	ON

To assign type of PowerWave Control Panel

	Switch 5	Switch 6	Switch 7
PW-4	OFF	OFF	OFF
PW-8	ON	OFF	OFF
PW-16	OFF	ON	OFF
PW-64 I	ON	ON	OFF
PW-64 II	OFF	OFF	ON

To set the Keypad tamper mode

	Switch 8
Disable Keypad Tamper	ON
Enable Keypad Tamper	OFF

www.thecrowgroup.com

support@crow.co.il